



US006613187B1

(12) **United States Patent**
Ding et al.

(10) **Patent No.:** **US 6,613,187 B1**

(45) **Date of Patent:** **Sep. 2, 2003**

(54) **SOLVENT BONDING METHOD FOR POLYOLEFIN MATERIALS**

FOREIGN PATENT DOCUMENTS

(75) Inventors: **Yuan-pang Samuel Ding**, Vernon Hills, IL (US); **Chuan Qin**, Gurnee, IL (US); **Lecon Woo**, Libertyville, IL (US); **Michael T. K. Ling**, Vernon Hills, IL (US)

DE	133411	1/1979	
DE	158035	* 12/1982	156/308.6
DE	251 904 A3	12/1987	
DE	39 37 865 A1	6/1990	
EP	0 156 464 A1	10/1985	
EP	0 216 509 B1	8/1986	
EP	0 283 164	3/1988	
EP	0 291 208	4/1988	
EP	0 291 208 A2	11/1988	
EP	0 492 982 B1	12/1991	

(73) Assignee: **Baxter International Inc**, Deerfield, IL (US)

(List continued on next page.)

(*) Notice: Subject to any disclaimer, the term of this patent is extended or adjusted under 35 U.S.C. 154(b) by 0 days.

OTHER PUBLICATIONS

(21) Appl. No.: **09/392,913**

Ticona Topas Cyclic Olefin Copolymers Preliminary Information.

(22) Filed: **Sep. 9, 1999**

Ullmann's Encyclopedia of Industrial Chemistry Plastics, General Survey—Thermal Properties (Hans-Georg Elias) Section 6.2.5 Glass Transitions.

(51) **Int. Cl.**⁷ **B32B 31/00**

Abstract only from JP 59053528-A.

(52) **U.S. Cl.** **156/334**; 524/490; 526/581

Abstract only from J03275052.

(58) **Field of Search** 524/490; 526/281; 156/334

Abstract only from J03275070.

Primary Examiner—Jeff H. Aftergut

(74) *Attorney, Agent, or Firm*—Mark J. Buonaiuto; Joseph A. Fuchs

(56) **References Cited**

ABSTRACT

U.S. PATENT DOCUMENTS

The present invention provides a method for using a polymeric cement to assemble medical devices. The method includes the steps of: (1) providing a first article of a low crystallinity polymer; (2) providing a second article of a low crystallinity polymer; (3) providing a cement composition having a first component of a cyclic olefin containing polymer or a bridged polycyclic hydrocarbon containing polymer and a second component of an effective amount of a solvent having a solubility parameter of less than about 20 (MPa)^{1/2}; applying the cement composition to one of the first and second articles to define a bonding area; and (4) attaching the first article to the second article along the bonding area to fixedly attach the first article to the second article.

2,971,876 A	*	2/1961	Phair	156/334
3,494,897 A		2/1970	Reding et al.	
3,514,359 A	*	5/1970	Frese	156/334
4,573,994 A		3/1986	Fischell et al.	
4,628,969 A		12/1986	Jurgens, Jr. et al.	
4,931,520 A	*	6/1990	Yamanashi et al.	526/281
4,992,511 A		2/1991	Yamamoto et al.	
5,003,019 A		3/1991	Ishimaru et al.	
5,008,356 A		4/1991	Ishimaru et al.	
5,087,677 A		2/1992	Brekner et al.	
5,207,983 A		5/1993	Liebert et al.	
5,218,049 A		6/1993	Yamamoto et al.	
5,272,235 A		12/1993	Wakatsuru et al.	
5,288,560 A		2/1994	Sudo et al.	
5,331,057 A		7/1994	Brekner et al.	

(List continued on next page.)

65 Claims, 1 Drawing Sheet

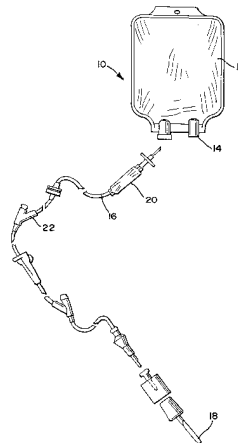

U.S. PATENT DOCUMENTS

5,359,001 A 10/1994 Epple et al.
 5,422,409 A 6/1995 Brekner et al.
 5,457,249 A 10/1995 Sagane et al.
 5,475,060 A 12/1995 Brekner et al.
 5,498,677 A 3/1996 Wellner et al.
 5,534,606 A 7/1996 Bennett et al.
 5,552,504 A 9/1996 Bennett et al.
 5,583,192 A 12/1996 Bennett et al.
 5,610,253 A 3/1997 Hatke et al.
 5,620,425 A 4/1997 Heffernan et al.
 5,629,398 A 5/1997 Okamoto et al.
 5,637,100 A 6/1997 Sudo
 5,637,400 A 6/1997 Brekner et al.
 5,650,471 A 7/1997 Abe et al.
 5,693,728 A 12/1997 Okamoto et al.
 5,698,645 A 12/1997 Weller et al.
 5,723,189 A 3/1998 Sudo
 5,733,991 A 3/1998 Rohrmann et al.
 5,744,664 A 4/1998 Brekner et al.
 5,756,623 A * 5/1998 Kreuder et al. 526/281
 5,788,670 A 8/1998 Reinhard et al.
 5,792,824 A 8/1998 Natori
 5,795,945 A 8/1998 Natori
 5,854,349 A 12/1998 Abe et al.
 5,863,986 A 1/1999 Herrmann-Schönherr et al.

5,872,201 A * 2/1999 Cheung et al. 526/281
 5,980,495 A 11/1999 Heinz et al.
 6,007,520 A 12/1999 Sudo
 6,065,270 A 5/2000 Reinhard et al.
 6,068,936 A 5/2000 Peiffer et al.

FOREIGN PATENT DOCUMENTS

EP 0 497 567 A2 1/1992
 EP 0 524 802 A1 1/1993
 EP 0 582 355 B1 2/1994
 EP 0 680 401 B1 11/1995
 EP 0 430 585 B1 1/1996
 EP 0 156 464 B1 5/1996
 EP 0 709 105 A1 5/1996
 EP 0 203 799 B1 8/1996
 EP 0 384 694 B1 9/1996
 EP 0 497 567 B1 9/1996
 EP 0 790 063 A1 8/1997
 JP 03095286 4/1991
 JP 05277154 10/1993
 JP 11071554 3/1999
 WO WO 97/08054 3/1997
 WO WO 98/27926 7/1998
 WO WO 98/44043 10/1998
 WO WO 99/48990 9/1999

* cited by examiner

FIG. 1

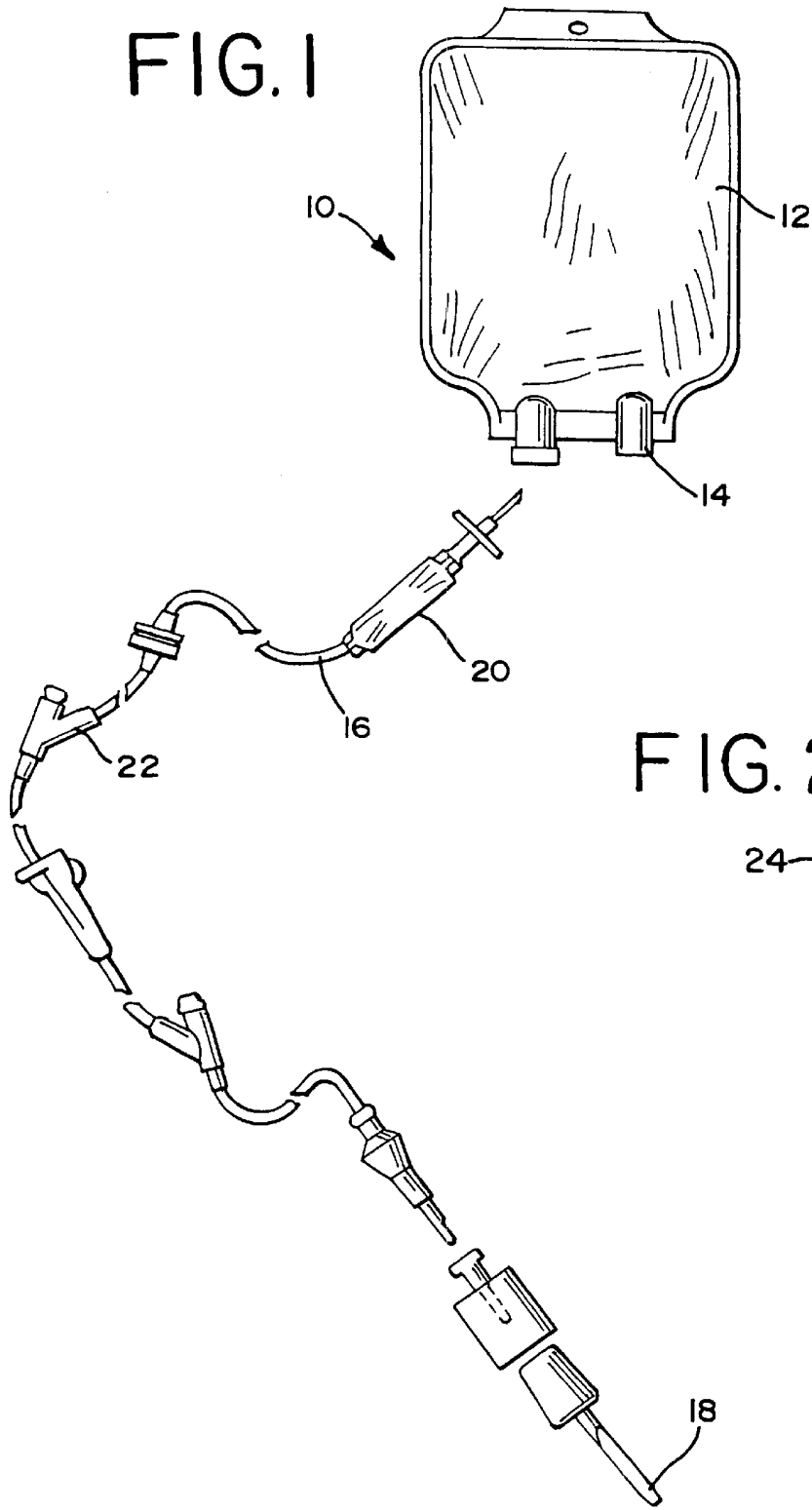
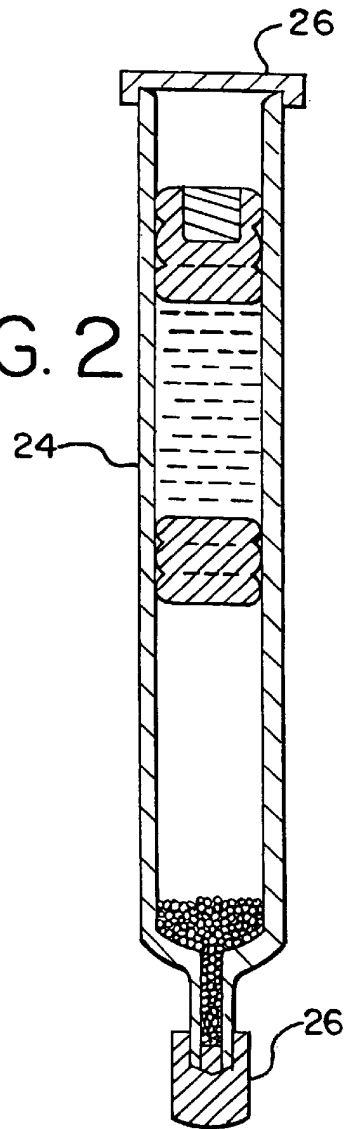

FIG. 2



SOLVENT BONDING METHOD FOR POLYOLEFIN MATERIALS

TECHNICAL FIELD

This invention relates to a composition for bonding olefin materials and in particular it relates to a cyclic olefin containing polymer cement composition or a bridged polycyclic hydrocarbon containing polymer cement composition for bonding olefin materials together and the devices resulting therefrom.

BACKGROUND ART

In the medical field, where beneficial agents are collected, processed and stored in containers, transported and ultimately delivered through drip chambers, tube connectors and tubes by infusion to patients, there has been a recent trend toward developing materials useful for fabricating such containers, tubings and devices without the disadvantages of currently used materials such as polyvinyl chloride. These new materials must have a unique combination of properties to be used in fluid administration sets. Among these are the materials in most instances must be optically clear, environmentally compatible, have sufficient yield strength and flexibility for flexible products and sufficient rigidity for rigid products, have a low quantity of low molecular weight additives, be capable of being solvent bonded to soft polyolefin medical products and be compatible with medical solutions.

It is desirable for medical products in an infusion delivery set to be optically transparent to allow for visual inspection of fluids therein.

It is also desirable that the medical materials be environmentally compatible as a great deal of medical products are disposed of in landfills and through incineration. Further benefits are realized by using a material which is thermoplastically recyclable.

For medical products that are disposed of by incineration, it is necessary to use a material that does not generate or minimizes the formation of by-products such as inorganic acids which may be environmentally harmful, irritating, and corrosive. For example, PVC may generate objectionable amounts of hydrogen chloride (or hydrochloric acid when contacted with water) upon incineration, causing corrosion of the incinerator.

To be compatible with medical solutions, it is desirable that the components of the infusion delivery set be free from or have a minimal content of low molecular weight additives such as plasticizers, stabilizers and the like. In some applications, these components can be extracted into the therapeutic solutions that come into contact with the material. The additives may react with the therapeutic agents or otherwise render the solution ineffective. This is especially troublesome in bio-tech drug formulations where the concentration of the drug is measured in parts per million (ppm), rather than in weight or volume percentages. Even minuscule losses of the bio-tech drug can render the formulation unusable. Because bio-tech formulations can cost several thousand dollars per dose, it is imperative that the dosage not be changed. Polyvinyl chloride ("PVC") has been widely used to fabricate medical tubings and containers as it meets most of these requirements. However, because PVC by itself is a rigid polymer, low molecular weight components known as plasticizers must be added to render PVC flexible. These plasticizers may leach out of the medical product and into the fluid passing through the products to contaminate the

fluid or to render the fluid unusable. For this reason, and because of the difficulties encountered in incinerating PVC, there is a need to replace PVC in at least the fluid contacting portions of the infusion pathway and more preferably in its entirety.

Polyolefins have been developed which meet many of the requirements of medical containers and tubing, without the disadvantages associated with PVC. Polyolefins typically are compatible with medical applications because they have minimal extractability to the fluids and contents which they contact. Most polyolefins are environmentally sound as they do not generate harmful degradants upon incineration, and in most cases are capable of being thermoplastically recycled. Many polyolefins are cost effective materials that may provide an economic alternative to PVC. However, there are many hurdles to overcome to replace all the favorable attributes of PVC with a polyolefin.

For example, because of the inert nature of polyolefins, due in part to the non-polar nature of the polymer, difficulties have been encountered in bonding the polyolefin materials to rigid housings positioned along the infusion pathway of an infusion set. Typically, medical containers such as I.V. bags are connected to a patient through a series of connected tubing that have in fluid communication drip chambers, Y-type injection sites, venous catheters and the like between the bag and the patient. Many of these components include rigid housings manufactured from polycarbonates, acrylics, ABS, copolyesters and the like. The housings have sleeves in which the tubing is inserted in a telescoping fashion to attach the tube to the housing. Therefore, it is necessary for the medical tubing to be connected to the rigid housing to form a fluid tight seal with the housings.

PVC, tubing is typically secured within such housings using solvent bonding techniques. Solvent bonding requires exposing the end of the tubing to be inserted into the housing to a solvent such as cyclohexanone or methyl ethyl ketone. The solvent effectively softens or dissolves the PVC so when the tubing is inserted into the housing, a bond is formed. Solvent bonding techniques, however, are ineffective on certain polyolefins including polyethylene and polypropylene. Problems have also been encountered in using adhesive bonding techniques.

European Patent Application No. 0 556 034 discloses a medical instrument of a material containing a resin of a cyclic olefin compound or a bridged polycyclic hydrocarbon compound. The EP '034 Application discloses making devices such as syringes, injection needles, drip chambers, blood bags and tubing from these resins. While the EP '034 Patent application discloses a non-PVC material for fabricating medical products it does not disclose a method for bonding a rigid housing of a cyclic olefin to a flexible tubing of a cyclic olefin or other polyolefins.

Cycloolefin blends are also well known for providing rigid, injection molded parts. For example, U.S. Pat. No. 5,359,001 discloses a multiple component polymer blend having a first component of a cycloolefin, a second component of a polyolefin and a third component of a cycloolefin block copolymer to compatibilize the cycloolefin and polyolefin. The '001 Patent discloses such blends for impact modifying the highly rigid and brittle cycloolefins. The '001 Patent does not disclose a method for solvent bonding these blends.

U.S. Pat. No. 5,863,986 discloses polymer alloy blends of a cycloolefin copolymers with one or more core-shell particles and one or more block copolymers. Again, these polymer blends are tough on impact and have high flexural

strength and elongation at break. The '986 patent does not disclose a method for solvent bonding the polymer alloy blends.

DISCLOSURE OF INVENTION

The present invention provides a method for using a polymeric cement to assemble medical devices. The method comprises the steps of: (1) providing a first article of a first polymeric material selected from the group comprising polyolefins, styrene containing polymers, cyclic olefin containing polymers and bridged polycyclic hydrocarbon containing polymers; (2) providing a second article of a polymeric material selected from the group comprising polyolefins, styrene containing polymers, cyclic olefin containing polymers and bridged polycyclic hydrocarbon containing polymers; (3) providing a cement composition having a first component of a cyclic olefin containing polymer or a bridged polycyclic hydrocarbon containing polymer and a second component of an effective amount of a solvent having a solubility parameter of less than about 20 (MPa)^{1/2}; (4) applying the cement composition to one of the first and second articles to define a bonding area; and (5) attaching the first article to the second article along the bonding area to fixedly attach the first article to the second article.

In a preferred form of the invention the method comprises the steps of: (1) providing a first article of a first polymeric material selected from the group comprising polyolefins, styrene containing polymers, cyclic olefin containing polymers and bridged polycyclic hydrocarbon containing polymers; (2) providing a second article of a polymeric material selected from the group comprising polyolefins, styrene containing polymers, cyclic olefin containing polymers and bridged polycyclic hydrocarbon containing polymers; (3) providing a cement composition comprising: (a) a first component obtained by copolymerizing a norbornene monomer and an ethylene monomer, the norbornene monomer being present in an amount of at least about 20 mole percent of the copolymer, the first component being present in an amount from about 1% to about 20% by weight of the composition; (b) an effective amount of a solvent having a solubility parameter of less than about 20 (MPa)^{1/2}; (c) an optional third component of a low crystallinity polymer, the third component being in an amount from about 0% to about 10% by weight of the composition; (4) applying the cement composition to one of the first and second articles to define a bonding area; and (5) attaching the first article to the second article along the bonding area to fixedly attach the first article to the second article.

The present invention also provides a medical device assembly. The assembly has a first article of a first polymeric material selected from the group comprising polyolefins, styrene containing polymers, cyclic olefin containing polymers and bridged polycyclic hydrocarbon containing polymers. The assembly also has a second article of a polymeric material selected from the group comprising polyolefins, styrene containing polymers, cyclic olefin containing polymers and bridged polycyclic hydrocarbon containing polymers. The first article is attached to the second article with a cement composition. The cement composition has a first component of a cyclic olefin containing polymer or a bridged polycyclic hydrocarbon containing polymer and an effective amount of a solvent having a solubility parameter of less than about 20 (MPa)^{1/2}.

BRIEF DESCRIPTION OF DRAWINGS

FIG. 1 shows a diagrammatic view of an infusion delivery set; and

FIG. 2 shows a diagrammatic view of a syringe barrel having end closures solvent bonded thereto.

BEST MODE FOR CARRYING OUT THE INVENTION

While the invention is susceptible of embodiment in many different forms, there is shown in the drawings and will herein be described in detail preferred embodiments of the invention with the understanding that the present disclosure is to be considered as an exemplification of the principles of the invention and is not intended to limit the broad aspect of the invention to the embodiments illustrated.

FIG. 1 shows an infusion delivery set **10** having an I.V. container **12** and port tube **14** connected to a tubing **16**, which provides at its distal end a venous catheter **18** for establishing fluid-flow access to a vascular system of a patient. Positioned at intermediate portions of the infusion pathway is a drip chamber **20** and a Y-type injection site **22**. It should be understood that other rigid medical housings include filter housings, tubing unions and others well known in the art, and that these components could be used in any combination in a delivery set **10**. FIG. 2 shows a syringe barrel **24** having end closures **26** solvent bonded on opposite ends of the syringe barrel. Of course the end closure **26** can be on one or both ends of the syringe barrel **24**.

As will be described below, the present invention provides polymers and copolymers containing monomers of cyclic olefins (which sometimes shall be referred to as cyclic olefin containing polymers) and blends thereof as well as homopolymers and copolymers containing monomers of bridged polycyclic hydrocarbons (which sometimes shall be referred to as bridged polycyclic hydrocarbon containing polymers) and blends thereof to fabricate both the flexible, rigid and semi-rigid components of the delivery set **10** and further provides solvent bonding and cement bonding techniques for attaching together olefin components to fabricate medical device assemblies and subassemblies contained in an infusion set or other medical devices well known in the medical arts.

The term polyolefin used herein is meant to include homopolymers and copolymers of ethylene, propylene, butene, pentene, hexene, heptene, octene, nonene, and decene. Suitable copolymers of ethylene include: (a) ethylene copolymerized with monomers selected from the group of α -olefins having 3–10 carbons, lower alkyl and lower alkene substituted carboxylic acids and ester and anhydride derivatives thereof, (b) ethylene propylene rubbers, (c) EPDM, and (d) ionomers. Preferably, the carboxylic acids have from 3–10 carbons. Such carboxylic acids therefore include acetic acid, acrylic acid and butyric acid. The term "lower alkene" and "lower alkyl" is meant to include a carbon chain having from 3–18 carbons more preferably 3–10 and most preferably 3–8 carbons. Thus, a subset of this group of comonomers includes, as a representative but non-limiting example, vinyl acetates, vinyl acrylates, methyl acrylates, methyl methacrylates, acrylic acids, methacrylic acids, ethyl acrylates, and ethyl acrylic acids.

I. Cyclic Olefins and Bridged Polycyclic Hydrocarbons

Suitable homopolymer and copolymers of cyclic olefins and bridged polycyclic hydrocarbons and blends thereof can be found in U.S. Pat. Nos. 4,874,808, 5,003,019, 5,008,356, 5,288,560, 5,218,049, 5,854,349, 5,863,986, 5,795,945, and 5,792,824, which are incorporated in their entirety herein by reference and made a part hereof. In a preferred form of the invention these homopolymers, copolymers and polymer blends will have a glass transition temperature of greater

than 50° C., more preferably from about 70° C. to about 180° C., a density greater than 0.910 g/cc and more preferably from 0.910 g/cc to about 1.3 g/cc and most preferably from 0.980 g/cc to about 1.3 g/cc and have from at least about 20 mole % of a cyclic aliphatic or a bridged polycyclic in the backbone of the polymer more preferably from about 30–65 mole % and most preferably from about 30–60 mole %.

Known processes for producing cyclo-olefinic copolymers by copolymerizing alpha-olefins such as ethylene and cyclo-olefins involve the use of titanium-containing catalysts comprising titanium compounds and organoaluminum compounds or vanadium-containing catalysts comprising vanadium compounds and organoaluminum compounds.

In a copolymerization process using a titanium-containing catalyst, a cyclo-olefin has lower reactivity than an alpha-olefin such as ethylene and the copolymerization efficiency is low. In order, therefore, to expect production of a copolymer of the cyclo-olefin with the alpha-olefin, it is necessary to add the cyclo-olefin in a large quantity to the polymerization system. The presence of a large quantity of the cyclo-olefin reduces the activity of the catalyst and may result in a decrease in the molecular weight of the resulting copolymer. It is difficult therefore to obtain a high-molecular-weight copolymer. Moreover, this process has the defect that side-reactions such as the ring-opening polymerization of the cyclo-olefin tend to occur, and the resulting polymer has a broad molecular weight distribution. On the other hand, in a copolymerization process using a vanadium-containing catalyst, the copolymerization efficiency of the cyclo-olefin is higher than in the case of using the titanium-containing catalyst and the resulting copolymer has a narrow molecular weight distribution. But it has the defect that the polymerization activity is generally very low.

Catalysts comprising transition metal compounds and aluminoxanes are proposed as highly active polymerization catalysts for olefins in, for example, Japanese Laid-Open Patent Publications Nos. 19309/1983, 95292/1984, 35005/1985, 35006/1985, 35007/1985 and 35008/1985. Of these, Japanese Laid-Open Patent Publications Nos. 19309/1983, 35005/1985, 35006/1985, 35007/1985 and 35008/1985 describe that these catalyst systems can be applied to the copolymerization of ethylene with other alpha-olefins. With regard to the production of cyclo-olefinic copolymers, Japanese Laid-Open Patent Publication No. 221206/1986 discloses a catalyst comprising a transition metal compound and an aluminoxane with regard to the production of a copolymer of an alpha-olefin and a cyclo-olefin. This catalyst, however, has low polymerization activity, and is difficult of giving the copolymer in good yields.

Japanese Laid-Open Patent Publication No. 127728/1983 proposes a homopolymer of 1,4,5,8-dimethano-1,2,3,4,4a,5,8,8a-octahydronaphthalene or a copolymer of the above cyclo-olefin and a norbornene-type comonomer. It is clear from this patent document that these copolymers are ring-opened polymers. These ring-opened polymers have poor thermal stability and heat aging resistance because they contain an unsaturated bond in the main polymer chain.

In a preferred form of the invention, suitable cyclic olefin monomers are monocyclic compounds having from 5 to about 10 carbons in the ring. The cyclic olefins can be selected from the group consisting of substituted and unsubstituted cyclopentene, cyclopentadiene, cyclohexene, cyclohexadiene, cycloheptene, cycloheptadiene, cyclooctene, cyclooctadiene. Suitable substituents include lower alkyl, acrylate derivatives and the like.

In a preferred form of the invention, suitable bridged polycyclic hydrocarbon monomers have two or more rings

and more preferably contain at least 7 carbons. The rings can be substituted or unsubstituted. Suitable substitutes include lower alkyl, aryl, aralkyl, vinyl, allyloxy, (meth)acryloxy and the like. The bridged polycyclic hydrocarbons are selected from the group consisting of those disclosed in the above incorporated patents and patent applications. Suitable bridged polycyclic hydrocarbon containing polymers are sold by Ticona under the tradename TOPAS, by Nippon Zeon under the tradename ZEONEX and ZEONOR, by Daikyo Gomu Seiko under the tradename CZ resin, and by Mitsui Petrochemical Company under the tradename APEL.

Suitable comonomers include α -olefins having from 2–10 carbons, aromatic hydrocarbons, other cyclic olefins and bridged polycyclic hydrocarbons.

It may also be desirable to have pendant groups associated with the above-mentioned homopolymers and copolymers. The pendant groups are for compatibilizing the cyclic olefin containing polymers and the bridged polycyclic hydrocarbon containing polymers with more polar polymers including amine, amide, imide, ester, carboxylic acid and other polar functional groups. Suitable pendant groups include aromatic hydrocarbons, carbon dioxide, monoethylenically unsaturated hydrocarbons, acrylonitriles, vinyl ethers, vinyl esters, vinylamides, vinyl ketones, vinyl halides, epoxides, cyclic esters and cyclic ethers. The monothienically unsaturated hydrocarbons include alkyl acrylates, and aryl acrylates. The cyclic ester includes maleic anhydride.

II. Blends Containing Cyclic Olefin Containing Polymers and/or Bridged Polycyclic Hydrocarbon Containing Polymers

Suitable two-component blends of the present invention include as a first component the homopolymers and copolymers of the cyclic olefin containing polymers and the bridged polycyclic hydrocarbon containing polymers (collectively hereinafter sometimes referred to as "COCs") described above in Section I. The COCs should be present in an amount from about 1–99% by weight of the blend, more preferably from about 30–99%, and most preferably from about 35–99 weight percent or any combination or subcombination or ranges therein. In a preferred form of the invention the first components has a glass transition temperature of from about 70° C. to about 130° C. and more preferably, from about 70–110° C.

The blends further include a second component in an amount by weight of the blend of from about 99–1%, more preferably from about 70–1% and most preferably from about 65–1%. The second component is selected from the group consisting of homopolymers and copolymers of ethylene, propylene, butene, hexene, octene, nonene, decene and styrene. The second component preferably has a density of from about 0.870–0.960 g/cc and more preferably from about 0.910–0.960 g/cc and more preferably from about 0.930–0.960 g/cc. In a preferred form of the invention the second component is an ethylene and α -olefin copolymer where the α -olefin has from 3–10 carbons, more preferably from 4–8 carbons and most preferably 6 carbons. Most preferably the ethylene and α -olefin copolymers are obtained using a metallocene catalyst.

Suitable three-component blends include as a third component a COC selected from those COCs described in Part I above and different from the first component. In a preferred form of the invention the second COC will have a glass transition temperature of higher than about 120° C. when the first COC has a glass transition lower than about 120° C. In a preferred form of the invention, the third component is present in an amount by weight of from about 10–90% by weight of the blend and the first and second components

should be present in a ratio of from about 2:1 to about 1:2 respectively of the first component to the second component.

In a preferred form of the invention, random and block copolymers of norbornene and ethylene are selected as the first component of the blend. These norbornene copolymers are described in detail in U.S. Pat. Nos. 5,783,273, 5,744, 664, 5,854,349, and 5,863,986. The norbornene ethylene copolymer preferably has from at least about 20 mole percent norbornene monomer and more preferably from about 20–75 mole percent and most preferably from about 30–60 mole percent norbornene monomer or any combination or subcombination of ranges therein. The norbornene ethylene copolymer should have a glass transition temperature of from about 70–180° C., more preferably from 70–130° C. and even more preferably from about 70–100° C.

The second component is preferably an ethylene copolymerized with an α -olefin having 6 carbons. It has been found by the present inventors that using this ethylene and a 6 carbon α -olefin as the second component yields blends with higher clarity when compared to blends having ethylene copolymerized with α -olefins having 4 or 8 carbons. Preferably, the ethylene and α -olefin copolymers are obtained using metallocene catalysts. Suitable catalyst systems, among others, are those disclosed in U.S. Pat. Nos. 5,783,638 and 5,272,236. Suitable ethylene and α -olefin copolymers include those sold by Dow Chemical Company under the AFFINITY and ENGAGE tradenames, those sold by Exxon under the EXACT tradename and those sold by Phillips Chemical Company under the tradename MAR-LEX.

As set forth above, the first component of the norbornene/ethylene copolymer can be present from about 1–99% by weight of the blend, more preferably from about 30–99% by weight, and most preferably 35–99% by weight.

In a preferred three-component blend a second norbornene and ethylene copolymer is added to the two component norbornene-ethylene/ethylene 6 carbon α -olefin blend. The second norbornene ethylene copolymer should have a norbornene monomer content of 30 mole percent or greater and more preferably from about 35–75 mole percent and a glass transition temperature of higher than 120° C. when the first component has a glass transition temperature of lower than 120° C.

III. Medical Products

Medical devices such as those shown in FIG. 1 may be fabricated from the COCs set forth above. The present invention provides for fabricating, rigid, semi-rigid and flexible devices from the COCs. What is meant by the use of the term “rigid” herein is parts having a modulus of elasticity of at least 150,000 psi when measured in accordance with ASTM D790. What is meant by the term “semi-rigid” is parts having a modulus of elasticity of greater than 20,000 psi but less than 150,000 psi when measured in accordance with ASTM D790. What is meant by the term “flexible” is articles having a modulus of elasticity of less than about 20,000 psi when measured in accordance with ASTM D790.

Rigid parts such as Y-sites, filter housings, injection sites, spikes, syringe barrels, closures and others may be fabricated from the COCs by injection molding, blow molding, thermoforming processes or other plastic fabricating techniques. Semi-rigid parts such as drip chambers and closures may be fabricated from injection molding, blow molding, thermoforming and extrusion processes. Flexible parts such as medical tubing, closures and medical containers may be obtained using extrusion, coextrusion, lamination, blow molding and injection molding processes.

For flexible and semi-rigid components such as tubing, containers and drip chamber 20, suitable polymers also include other polyolefins such as ethylene vinyl acetate copolymers having a vinyl acetate content of from about 5% to about 32%, ethylene methacrylate copolymers, ethylene and α -olefin copolymers having a density of less than 0.910 g/cc, flexible polypropylenes such as Huntsman’s REFLEX and Montell’s ADFLEX and stereo block homopolymers of polypropylene disclosed in U.S. Pat. No. 5,594,080. Suitable polymers also include polymer blends and films such as those disclosed in U.S. Pat. No. 5,849,843 and U.S. patent application Ser. No. 08/153,602.

IV. Method of Solvent Bonding COCs

The present invention provides a method for assembling components of an infusion set into medical assemblies using solvent bonding techniques. Solvent bonding techniques can be used to join together any combination of rigid, semi-rigid and flexible parts including joining two rigid components, a rigid component to a semi-rigid component, a rigid component to a flexible component, a semi-rigid component to a flexible component, a semi-rigid component to another semi-rigid component, and certain flexible components to one another.

The method of solvent bonding includes the steps of: (1) providing a first article of a polymer composition described above in Sections I and II such as those having a first component of cyclic olefin containing polymer or a bridged polycyclic hydrocarbon containing polymer, the first component being present in an amount from about 30% to about 100% by weight of the composition; (2) providing a second article of a material selected from the group comprising low crystallinity polymers; (3) applying a solvent to one of the first article or the second article to define an interface area; and (4) bonding the first article to the second article along the interface area. Suitable low crystallinity polymers to fabricate the second article include COCs, COC blends having minimally 30% COC by weight, polymethyl pentene, polyolefins having a modulus of elasticity of less than 10,000 psi when measured in accordance with ASTM D790, and styrene containing polymers without modulus limitations.

Suitable solvents are those having a solubility parameter of less than about 20 (MPa)^{1/2} more preferably less than about 19 (MPa)^{1/2} and most preferably less than about 18 (MPa)^{1/2} and include, but are not limited to, aliphatic hydrocarbons, aromatic hydrocarbons, mixtures of aliphatic hydrocarbons, mixtures of aromatic hydrocarbons and mixtures of aromatic and aliphatic hydrocarbons. Suitable aliphatic hydrocarbons include substituted and unsubstituted hexane, heptane, cyclohexane, cycloheptane, decalin, and the like. Suitable aromatic hydrocarbons include substituted and unsubstituted aromatic hydrocarbon solvents such as xylene, tetralin, toluene, and cumene. Suitable hydrocarbon substituents include aliphatic substituents having from 1–12 carbons and include propyl, ethyl, butyl, hexyl, tertiary butyl, isobutyl and combinations of the same. What is meant by the terms “aliphatic hydrocarbon” and “aromatic hydrocarbon” is a compound containing only carbon and hydrogen atoms. Suitable solvents will also have a molecular weight less than about 200 g/mole, more preferably less than about 180 g/mole and most preferably less than about 140 g/mole.

The first article can be rigid, semi-rigid and flexible medical product selected from the group consisting of Y-sites, filter housings, drip chambers, heparin locks, injection sites, catheters, spikes, syringe barrels, closures, tubings, oxygenators, pump cassettes, valves, burretes, and

any medical article or component. The second article can be rigid, semi-rigid and flexible polymeric material selected from the group comprising polyolefins, styrene containing polymers, cyclic olefin containing polymers and bridged polycyclic hydrocarbon containing polymers. The second article can be of the same device set forth for the first article.

In a preferred form of the invention, the method comprises the steps of: (1) providing a first article of a polymer composition comprising: (a) a first component obtained by polymerizing a norbornene monomer and an ethylene monomer, the norbornene monomer being present in an amount of at least about 20 mole percent of the copolymer, the first component being present in an amount from about 30% to about 100% by weight of the composition; and (b) a second component of a first ethylene and α -olefin copolymer, the second component being in an amount from about 70% to about 0% by weight of the composition; (2) providing a second article of a material selected from the group comprising low crystallinity polymers; (3) applying a solvent to one of the first article or the second article to define an interface area; and (4) bonding the first article to the second article along the interface area.

V. COC Cement

For those flexible polymers that do not bond well to other flexible polymers using the solvent bonding techniques described above in Section IV, the present invention provides a cyclic olefin containing polymer based cement composition or bridged polycyclic hydrocarbon containing polymer based cement composition. The first component of the cement composition is selected from those set forth in Section I above and include a homopolymer or copolymer of a cyclic olefin or a bridged polycyclic hydrocarbon in an amount from 1–20% by weight of the composition, more preferably from 1–15% and most preferably from 3–10%, and a second component of a solvent having a solubility parameter of less than about 20 (Mpa)^{1/2} more preferably less than about 19 (Mpa)^{1/2} and most preferably less than about 8 (Mpa)^{1/2} and more preferably selected from the group of aliphatic hydrocarbons and aromatic hydrocarbons set forth above in Section IV. Suitable solvents will also have a molecular weight less than about 200 g/mole, more preferably less than about 180 g/mole and most preferably less than about 140 g/mole.

These cement compositions can also be used for bonding flexible articles to rigid articles, flexible articles to semi-rigid articles, semi-rigid articles to one another or for bonding semi-rigid articles to rigid articles or for bonding rigid articles to one another. Accordingly, the cement compositions can be used to prepare medical device assemblies such as joining flexible tubings to one another, joining flexible tubings to tubing unions and flexible tubings to drip chambers, flexible tubings to Y-sites and other rigid housings or any of the components of the medical infusion set or other medical device assemblies.

It may also be desirable to include in the cement composition polymer resins from the articles being joined. These optional components can be added in an amount by weight of the composition from 0–10%, more preferably from 0.2–5% and most preferably from 0.2–3%. The third component can be selected from the group comprising polyethylene copolymers having a density less than 0.880 g/cc, polymethyl pentene, polypropylene having a modulus of less than 10,000 psi and more preferably less than 4,000 psi, and certain styrene containing copolymers and interpolymers. Typically these flexible type polypropylenes are atactic. Certain polypropylene copolymers with ethylene are also suitable. Suitable styrene containing polymers include

Dow's interpolymer of styrene sold under the tradename INDEX. Other suitable styrene containing polymers include SBS, SIS and hydrogenated derivatives thereof such as SEBS and SEPS.

The method of using a polymeric cement to assemble medical devices comprises the steps of: (1) providing a first article of a low crystallinity polymer set forth above, (2) providing a second article of a low crystallinity polymer set forth above; (3) providing a cement composition having a first component of a cyclic olefin containing polymer or a bridged polycyclic hydrocarbon containing polymer and a second component of an effective amount of a solvent having a solubility parameter of less than about 20 (MPa)^{1/2} and more preferably selected from the group of aliphatic hydrocarbons and aromatic hydrocarbons having a molecular weight less than about 200 g/mole; (4) applying the cement composition to one of the first and second articles to define a bonding area; and (5) attaching the first article to the second article along the bonding area to fixedly attach the first article to the second article.

Suitable polyolefins for the first and second articles can be selected from the group comprising homopolymers and copolymers of ethylene, propylene, butene, pentene, hexene, heptene, octene, nonene, and decene. Suitable copolymers of ethylene include: (a) ethylene copolymerized with monomers selected from the group of α -olefins having 3–10 carbons, lower alkyl and lower alkene substituted carboxylic acids and ester and anhydride derivatives thereof, (b) ethylene-propylene rubbers, (c) EPDM, and (d) ionomers. Preferably, the carboxylic acids have from 3–10 carbons. Such carboxylic acids therefore include acetic acid, acrylic acid and butyric acid. The term "lower alkene" and "lower alkyl" is meant to include a carbon chain having from 3–18 carbons more preferably 3–10 and most preferably 3–8 carbons. Thus, a subset of this group of comonomers includes, as a representative but non-limiting example, vinyl acetates, vinyl acrylates, methacrylates, methyl methacrylates, acrylic acids, methyl acrylic acids, ethyl acrylates, and ethyl acrylic acids.

The first component of the cement composition can also be a copolymer of the cyclic olefins or the bridged polycyclic hydrocarbons set forth above in Section I. Suitable comonomers of the COCs can be selected from the group comprising α -olefins having from 2–10 carbons, aromatic hydrocarbons, cyclic hydrocarbons, and bridged polycyclic hydrocarbons. In a preferred form of the invention the first component is a copolymer of a norbornene monomer and an ethylene monomer and more preferably the norbornene monomer is present in at least about 20 mole percent of the copolymer and even more preferably the norbornene is present from about 30 to about 60 mole percent.

The cement composition can also have an additional optional component selected from the group of polyethylene copolymers having a density less than about 0.880 g/cc, polymethyl pentene, polypropylene having a modulus of less than about 10,000 psi and more preferably less than about 4,000 psi, and certain styrene containing copolymers and interpolymers. Typically these flexible type polypropylenes are atactic. Certain polypropylene copolymers with ethylene are also suitable. Suitable styrene and ethylene containing polymers include Dow's interpolymer of styrene sold under the tradename INDEX. Other suitable styrene containing polymers include SBS, SIS and hydrogenated derivatives thereof such as SEBS and SEPS.

In a preferred form of the invention, the method for using a polymeric cement to assemble medical devices comprises the steps of: (1) providing a first article of a low crystallinity

polymer set forth above; (2) providing a second article of a low crystallinity polymer set forth above; (3) providing a cement composition comprising: (a) a first component in an amount by weight of from 1–20% of the cement composition and obtained by copolymerizing a norbornene monomer and an ethylene monomer, the norbornene monomer being present in an amount of at least about 20 mole percent of the copolymer; (b) a second component of a solvent in an amount by weight from about 99% to about 80% of the cement composition; and (c) an optional third component in an amount by weight from about 0–10% by weight of the cement composition and selected from the group of optional components set forth above; (4) applying the cement composition to one of the first and second articles to define a bonding area; and (5) attaching the first article to the second article along the bonding area to fixedly attach the first article to the second article.

The present invention also provides a medical device assembly. The assembly has a first article of a first polymeric material selected from the group comprising polyolefins, styrene containing polymers, cyclic olefin containing polymers and bridged polycyclic hydrocarbon containing polymers. The assembly also has a second article of a polymeric material selected from the group comprising polyolefins, styrene containing polymers, cyclic olefin containing polymers and bridged polycyclic hydrocarbon containing polymers. The first article is attached to the second article with a cement composition. The cement composition has a first component of a cyclic olefin containing polymer or a bridged polycyclic hydrocarbon containing polymer and an effective amount of a solvent having a solubility parameter of less than about 20 (MPa)^{1/2} and more preferably selected from the group of aliphatic hydrocarbons and aromatic hydrocarbons having a molecular weight less than about 200 g/mole. The following are non-limiting examples of the present invention

EXAMPLES

Example I

Test Methods for Resin Properties

Tensile Modulus: ASTM D638.

Flexural Modulus: ASTM D790.

Glass Transition Temperature: DSC.

Light Transmittance: ASTM D1003.

Example II

Resin Properties

(1) COC Resins

Topas resins are produced by Ticona, a member of the Hoechst Group.

CZ Resin is marketed by the Daikyo Gomu Seiko and The West Company.

Zeonex resin is produced by Nippon Zeon Co., Ltd.

Resin	Glass Transition Tg, (° C.)	Tensile Modulus (kpsi)	Light Transmittance (%)
Topas 8007	85	377	92
Topas 6013	130	464	92
Topas 6015	160	464	92

-continued

Resin	Glass Transition Tg, (° C.)	Tensile Modulus (kpsi)	Light Transmittance (%)
Topas 6017	180	464	92
CZ Resin	140	341	91
Zeonex 280	140	341	91

(2) Non-COC Resins

Material	Tensile/Flexural Modulus (kpsi)	Density (g/cc)	Comonomer
<u>Polyethylene:</u>			
Dow Chemicals Affinity VP8770	5	0.885	Octene
Dow Chemicals Affinity PL1880	12	0.903	Octene
Du Pont Dow Engage 8003	5	0.885	Octene
Du Pont Dow Engage 8411	3	0.880	Octene
Dow Chemicals Dowlex 2045	38	0.920	Octene
Mitsui Tafmer A4085	5	0.885	Butene
Exxon Exact 3024	14	0.905	Butene
Exxon Exact 3128	12	0.900	Butene
Exxon Exact 4033	3	0.880	Butene
Exxon Exact 3030	14	0.905	Hexene
Exxon Exact 3131	11	0.900	Hexene
Phillips Marlex mPACT D143	23	0.916	Hexene
Phillips Marlex mPACT D350	64	0.933	Hexene
<u>Polypropylene:</u>			
Huntsman Rexflex W304	2	0.88	
Huntsman Rexflex W210	4	0.89	
<u>EVA</u>			
Du Pont Elvax CM576	2.5	0.95	
<u>Polybutene</u>			
Montell PB0200	35	0.915	
Montell PB8340	32	0.908	
<u>Styrenic copolymer</u>			
Phillips K-Resin KR03	210	1.01	
Shell Kraton G 1657	0.4	0.90	

(3) Solvents Used in the Examples

All solvents were purchased from the Sigma-Aldrich Co.

The solubility parameters reported below are the Hansen Solubility Parameters at 25 degree C., as listed in the Polymer Handbook, 3rd Ed., Chapter VII, Pages 540–544 unless otherwise specified.

Solvent	Solubility Parameter(MPa) ^{1/2}	Molecular Weight (g/mol)	Type of compound
Cyclohexane	16.8	84	Aliphatic hydrocarbon (or Alkane)
Methyl cyclohexane	16.0	98	Aliphatic hydrocarbon
Ethyl cyclohexane	16.3*	112	Aliphatic hydrocarbon
Propyl cyclohexane	16.2*	126	Aliphatic hydrocarbon
n-Butyl cyclohexane	16.2*	140	Aliphatic hydrocarbon
t-Butyl cyclohexane	—	140	Aliphatic hydrocarbon
Decalin	18.0–18.8	138	Aliphatic hydrocarbon
Heptane	15.3	100	Aliphatic hydrocarbon
Xylene	18.0	106	Aromatic hydrocarbon
Tetralin	20.0	132	Aromatic hydrocarbon
Cumene	17.6*	120	Aromatic hydrocarbon
Toluene	18.2	92	Aromatic hydrocarbon
Cyclohexanone	19.6	98	Ketone
Methyl ethyl ketone	19.0	72	Ketone
Methylene chloride	20.3	85	Halohydrocarbon
Tetrahydrofuran	19.4	72	Ether
Dimethyl formamide	24.8	73	Nitrogen containing compound
Dimethyl sulfoxide	26.6	78	Sulfur containing Compound

*Data from CRC Handbook of Solubility Parameters and Other Cohesion Parameters, 2nd Ed.

25

Example III

Test Articles and Solvent Bonding Test Results

All the COC blends set forth in the table below were prepared using a Brabender mixer, mixed at 250° C. at 50 rpm for about 4 minutes, and then compression molded into 0.010" to 0.025" thick sheets at 450° F.

COC Blend Composition	Blend Ratio (wt %)	Material Rigidity	Strength of Solvent Bonding ⁽¹⁾		
			to ULDPE ⁽²⁾ (flexible)	to EVA ⁽³⁾ (flexible)	to COC ⁽³⁾ (rigid)
Topas 8007/Tafmer A4085	0/100	flexible	none	none	good
	30/70	semi-rigid	weak	weak	good
	50/50	rigid	good	good	strong
	70/30	rigid	strong	strong	strong
Topas 8007/Affinity VP8770	0/100	flexible	none	none	good
	50/50	rigid	good	good	strong
Topas 8007/Affinity PL1880	0/100	flexible	none	none	weak
	50/50	rigid	good	good	strong
Topas 8007/Engage 8411	0/100	flexible	none	none	good
	50/50	rigid	good	good	strong
Topas 8007/Exact 3024	0/100	flexible	none	none	weak
	50/50	rigid	good	good	strong
	70/30	rigid	strong	strong	strong
Topas 8007/Exact 3128	0/100	flexible	none	none	weak
	50/50	rigid	good	good	strong
Topas 8007/Exact 4033	0/100	flexible	none	none	good
	50/50	rigid	good	good	strong
Topas 8007/Engage8003	30/70	semi-rigid	weak		
	40/60	rigid	good		
	50/50	rigid	good		
	60/40	rigid	strong		
	70/30	rigid	strong		
	80/20	rigid	strong		
	90/10	rigid	strong		
Topas 6017/Dowlex 2045	0/100	semi-rigid	none	none	none
	50/50	rigid	good	good	strong
Topas 6015/Tafmer A4085	30/70	rigid	weak	weak	good
	50/50	rigid	good	good	strong
	70/30	rigid	good	good	strong

-continued

COC Blend Composition	Blend Ratio (wt %)	Material Rigidity	Strength of Solvent Bonding ⁽¹⁾		
			to ULDPE ⁽²⁾ (flexible)	to EVA ⁽³⁾ (flexible)	to COC ⁽³⁾ (rigid)
Topas 8007/Rexflex W304	0/100	flexible	none	none	good
	30/70	semi-rigid	weak	weak	good
	50/50	rigid	good	good	strong
	70/30	rigid	strong	strong	strong
Topas 8007/PB0200	0/100	semi-rigid	none	none	none
	50/50	rigid	good	good	strong
Topas 8007/PB8340	0/100	semi-rigid	none	none	none
	50/50	rigid	good	good	strong
Topas 6015/PB0200	50/50	rigid	good	good	strong
Topas 6015/PB8340	50/50	rigid	good	good	strong
Topas 8007/Kraton G1657	0/100	flexible	none	none	good
	30/70	semi-rigid	weak	weak	good
	50/50	rigid	good	good	strong
Topas 8007/K-Resin KR01	0/100	rigid	none	none	weak
	50/50	rigid	good	good	strong
	50/50	rigid	good	good	strong
Topas 6015/Tafimer A4085/KratonG1657	60/20/20	rigid	good	good	strong
Topas 6017/Topas 8007/Affinity VP8770	25/25/50	rigid	good	good	strong
	30/20/50	rigid	good	good	strong
Topas 6015/Topas 8007/Affinity VP8770	25/25/50	rigid	good	good	strong

⁽¹⁾The solvent used is cyclohexane.

Bond strength was assessed by hand pull test, at one day after the solvent bonding.

Ratings:

None = Readily separable.

Weak = Some bond strength but easy to separate.

Good = Hard to separate, no material transfer is visible on the peeled surface but is suitable for providing a sterile, sturdy connection.

Strong = Very hard to separate, material transferring from one surface to another at the peeling bonding interface is visible.

⁽²⁾The ULDPE specimen was made from Dow Chemicals Engage 8003 resin and was extruded into a tube.

⁽³⁾The EVA specimen was made from DuPont Elvax CM576 resin which had 28% VA content, and was extruded into a tube.

⁽⁴⁾The COC specimen was made from Topas 8007 resin and was injection molded into y-site with the bonding site in a tube geometry.

IV. Examples of Using Different Solvents to Bond
COC Containing Devices

-continued

Combination	Material-1 to Material-2	Solvent	Bond Strength		Combination	Material-1 to Material-2	Solvent	Bond Strength
Rigid to Flexible	Topas 8007 ^(a) to Engage 8003 ^(b)	Cyclohexane	good	45	Rigid to Rigid	Topas 8007 ^(c) to Topas 8007 ^(c)	Cumene	good
		Ethyl cyclo hexane	good				Toluene	weak
		Propyl cyclo hexane	good				Cyclohexanone	none
		n-Butyl cyclo hexane	good				Methyl ethyl ketone	none
		t-Butyl cyclo hexane	good				Methylene chloride	none
		Xylene	good				Tetrahydrofuran	none
		Tetralin	good				Dimethyl formamide	none
		Decalin	good				Dimethyl sulfoxide	none
		Heptane	good				Cyclohexane	strong
		Cumene	good				n-Butyl cyclo hexane	strong
		Toluene	weak				Xylene	strong
		Cyclohexanone	none				Tetralin	strong
		Methyl ethyl ketone	none				Heptane	strong
		Methylene chloride	none					
Tetrahydrofuran	none							
Dimethyl formamide	none							
Dimethyl sulfoxide	none							
Rigid to Flexible	Topas 8007 ^(a) to Elvax CM576 ^(b)	Cyclohexane	good	60				
		Ethyl cyclo hexane	good					
		Propyl cyclo hexane	good					
		n-Butyl cyclo hexane	good					
		t-Butyl cyclo hexane	good					
		Xylene	good					
		Tetralin	good					
Decalin	good							
Heptane	good							

Note:
^(a)Injection molded into y-site.
^(b)Extruded tubing.
^(c)Compression molded sheet.

Bond strength was assessed by hand pull test, at one day after the solvent bonding.

Ratings

None=Readily separable.
Weak=Some bond strength but easy to separate.
Good=Hard to separate, no material transfer is visible on the peeled surface but is suitable for providing a sterile, sturdy connection.

Strong=Very hard to separate, material transferring from one surface to another at the peeled bonding interface is visible.

V. Examples of Cements Made by Dissolving the COC Resin in Solvents for Bonding Flexible Polyolefin Components

The COC cements were prepared by dissolving the COC into a solvent at room temperature. Elevated temperature such as 50° C. can be used to enhance the speed of the preparation of the cement solution.

Cement formulation	Composition
A	coc resin: Topas 8007 1% wt solvent: Cyclohexane 99% wt
B	coc resin: Topas 8007 5% wt solvent: Cyclohexane 95% wt
C	coc resin: Topas 8007 15% wt solvent: Cyclohexane 85% wt
D	coc resin: Topas 8007 5% wt solvent: n-Butyl cyclohexane 95% wt
E	coc resin: Topas 8007 5% wt solvent: Decalin 95% wt
F	coc resin: Topas 8007 5% wt solvent: Heptane 95% wt
G	coc resin: Topas 5013 5% wt solvent: Cyclohexane 95% wt
H	coc resin: Topas 5013 20% wt solvent: Cyclohexane 80% wt

VI. Examples of Bonding a Flexible Component to a Flexible Component Using COC Cement
Compositions of Example IV

Tubings made of ULDPE (Engage 8003) or EVA (Elvax CM 576) were extruded and cut into segments. Cement was applied between bonding interfaces of the tubing segments identified in the following table. The bonding was done by applying small amount of the cement at the bonding interface. Bond strength was measured by a hand pull test conducted one day after bonding.

Flexible to flexible bonding	Cement	Bond Strength
Engage 8003 to Engage 8003	A	weak
Engage 8003 to Engage 8003	B	good
Engage 8003 to Engage 8003	C	good
Engage 8003 to Engage 8003	D	good
Engage 8003 to Engage 8003	E	good
Engage 8003 to Engage 8003	F	good
Elvax CM 576 to Elvax CM 576	A	weak
Elvax CM 576 to Elvax CM 576	B	good
Elvax CM 576 to Elvax CM 576	C	good
Elvax CM 576 to Elvax CM 576	D	good
Elvax CM 576 to Elvax CM 576	E	good
Elvax CM 576 to Elvax CM 576	F	good
Elvax CM 576 to Elvax CM 576	G	good
Elvax CM 576 to Elvax CM 576	H	good

Bond strength was assessed by hand pull test, at one day after the bonding.

Ratings:

None = Readily separable.

Weak = Some bond strength but easy to separate.

Good = Hard to separate, no material transfer is visible on the peeled surface but is suitable for providing a sterile, sturdy connection.

Strong = Very hard to separate, material transferring from one surface to another at the peeled bonding interface is visible.

VI. COC Blends

Blends of the components set forth in the following table were prepared with a Brabender mixer at 250° C. at 50 rpm

for 4 minutes. Films were prepared by compression molding at 450° F. to a thickness about 0.4 mm. The Haze property is useful for the end user to see through the medical device for the purpose of examining the liquid level, particulates, contamination, or the presence of drugs. Lower haze gives clearer view and higher haze gives a fuzzy view. Low haze is frequently a desirable property for medical devices such as solution containers, drug delivery devices, I.V. and blood sets, dialysis devices, and syringes.

The haze and total light transmittance of the film were measured using a ColorQuest instrument with both sides of the film wetted with isopropyl alcohol to remove the effect of surface roughness.

Example VI A

Blends of COC with Styrenic Copolymers and Polypropylene

COC Blend Composition	Blend Ratio (wt %)	Light Transmittance (%)	Haze (%)
Topas 8007/Rexflex W304	30/70	70	85
	50/50	75	83
	70/30	75	81
Topas 8007/Kraton G1657	30/70	64	86
	50/50	82	80
	70/30	84	80
Topas 8007/K-Resin KR01	50/50	72	83
	50/50	58	86

Examples VI B-D

Blends of COC with Polyethylene

Summary

The polymer blends that have lower haze, i.e. better clarity, are Topas 8007 blended with ethylene copolymers that have hexene comonomer polymerized with metallocene catalyst. The blends with the lowest haze are from the blends with polyethylene with hexene comonomer, polymerized with a metallocene catalyst and with a density of higher than 0.900 and more preferably higher than 0.93 (e.g. Marlex D350).

Example VI B

Blends of Topas 8007 (Tg~80 deg C.) and Polyethylene with Different Comonomers

COC Blend Composition	Blend Ratio	Comonomer in Polyethylene	Light Transmittance (%)	Haze (%)
Topas 8007/Tafmer A4085	30/70	Butene	84	80
	50/50		89	70
	70/30		81	61
Topas 8007/Exact 3024	50/50	Butene	88	83
	50/50	Butene	88	77
	50/50	Butene	81	81
Topas 8007/Exact 4033	50/50	Hexene	93	60
	50/50	Hexene	84	64
	30/70	Hexene	87	53
Topas 8007/MarlexD143	50/50		91	58
	70/30		90	52
	20/80	Hexene	89	54
Topas 8007/MarlexD350	30/70		87	44
	50/50		91	46

-continued

COC Blend Composition	Blend Ratio	Comonomer in Polyethylene	Light Transmittance (%)	Haze (%)
	70/30		91	45
	90/10		92	25
Topas 8007/Affinity VP8770	50/50	Octene	85	72
Topas 8007/Affinity PL1880	50/50	Octene	90	77
Topas 8007/Engage 8411	50/50	Octene	91	84

Example VI C

Blends of Topas 6015 (T_g~160 deg C.) and Polyethylene with Different Comonomers.

COC Blend Composition	Blend Ratio	Comonomer in Polyethylene	Light Transmittance (%)	Haze (%)
Topas 6015/Tafmer TFB-01	30/70	Butene	65	84
	50/50		78	85
	70/30		47	85
Topas 6015/MarlexD143	30/70	Hexene	76	85
	50/50		83	83
	70/30		77	79
Topas 6015/MarlexD350	30/70	Hexene	54	81
	50/50		80	72
	70/30		79	76
Topas 6015/Exact 3030	30/70	Hexene	86	84
	50/50		82	84
	70/30		62	83

Example VI D

Blends of Topas 6017 (T_g~180 deg C.), Topas 8007 (T_g~80 deg C.) and Polyethylene with Different Comonomers

CONCLUSION

The Blend that has Reduced Haze Contains Topas 8007 and a Metallocene Catalyst Polymerized Ethylene-hexene Copolymer.

COC Blend Composition	Blend Ratio	Comonomer in Polyethylene	Light Transmittance (%)	Haze (%)
Topas 6017/Topas 8007/Affinity VP8770	25/25/50	Octene	65	85
	30/20/50		69	85
Topas 6017/Topas 8007/Marlex D350	15/15/70	Hexene	91	69
	25/25/50		82	75
	35/35/30		89	42

It should be understood that any ranges or sets of ranges set forth herein includes any and all ranges, combination or subcombination of ranges therein.

While specific embodiments have been illustrated and described, numerous modifications are possible without departing from the spirit of the invention, and the scope of protection is only limited by the scope of the accompanying claims.

We claim:

1. A method for using a polymeric cement to assemble medical devices comprising the steps of:

providing a first article of a first low crystallinity polymer; providing a second article of a second low crystallinity polymer;

wherein the first low crystallinity polymer and the second low crystallinity polymer are selected from the group consisting of:

- (a) a homopolymer of a polyolefin,
- (b) a copolymer having a first monomer selected from the group consisting of propylene, butene, pentene, hexene, heptene, octene, nonene and decene,
- (c) ethylene copolymerized with monomers selected from the group of α -olefins having 3–10 carbons, lower alkyl and lower alkene substituted carboxylic acids and esters and anhydride derivatives thereof,
- (d) ethylene-propylene rubbers,
- (e) EPDM,
- (f) ionomers,
- (g) homopolymers of cyclic olefins,
- (h) copolymers of cyclic olefins selected from the group consisting of substituted and unsubstituted cyclopentene, cyclopentadiene, cyclohexene, cyclohexadiene, cycloheptadiene, cyclooctene, and cyclooctadiene, copolymerized with a fourth monomer selected from the group consisting of α -olefins having from 2–10 carbons, cyclic olefins, bridged polycyclic hydrocarbons and aromatic hydrocarbons,

- (i) homopolymers of bridged polycyclic hydrocarbons, and
- (j) and copolymers of bridged polycyclic hydrocarbons containing more than 7 carbons with a fifth monomer selected from the group of α -olefins having from 2–10 carbons, cyclic olefins, bridged polycyclic hydrocarbons and aromatic hydrocarbons;

providing a cement composition having a first component of a polymer obtained from an addition-polymerization process, the polymer having a backbone containing a cyclic olefin or a bridged polycyclic hydrocarbon wherein the cyclic olefin or bridged polycyclic hydrocarbon constitutes at least about 20 mole percent of the backbone, and a second component of an effective amount of a hydrocarbon solvent having a solubility parameter of less than about 20 (MPa)^{1/2} and a molecular weight of less than about 200 g/mole;

applying the cement composition to one of the first and second articles to define a bonding area; and

attaching the first article to the second article along the bonding area to fixedly attach the first article to the second article.

2. The method of claim 1 wherein the low crystallinity polymer is a homopolymer of polyethylene, or a homopolymer polymethyl pentene.

3. The method of claim 1 wherein the cyclic olefin of the cement composition has from 5 to about 10 carbons in the ring.

4. The method of claim 3 wherein the cyclic olefin is selected from the group consisting of substituted and unsubstituted cyclopentene, cyclopentadiene, cyclohexene, cyclohexadiene, cycloheptene, cycloheptadiene, cyclooctene, cyclooctadiene.

5. The method of claim 1 wherein the bridged polycyclic hydrocarbon of the cement composition has at least 7 carbons.

6. The method of claim 5 wherein the bridged polycyclic hydrocarbons have at least two rings.
7. The method of claim 6 wherein the bridged polycyclic hydrocarbon is norbornene.
8. The method of claim 1 wherein the first component of the cement composition is obtained by copolymerizing the cyclic hydrocarbon or the bridged polycyclic hydrocarbon with a comonomer.
9. The method of claim 8 wherein the comonomer is selected from the group comprising α -olefins having from 2–10 carbons, aromatic hydrocarbons, cyclic hydrocarbons, and bridged polycyclic hydrocarbons.
10. The method of claim 9 wherein the first component is a copolymer of a norbornene monomer and an ethylene monomer.
11. The method of claim 10 wherein the norbornene monomer is present in at least about 20 mole percent of the copolymer.
12. The method of claim 11 wherein the norbornene is present from about 30 to about 60 mole percent.
13. The method of claim 12 wherein the glass transition temperature of the first component is from about 70° C. to about 180° C.
14. The method of claim 1 wherein the cement composition has a third component of a polymer selected from the group consisting of polyethylene copolymers having a density less than 0.880 g/cc, polymethyl pentene, polypropylene having a modulus of less than 10,000 psi, styrene containing copolymers and styrene containing interpolymers.
15. The method of claim 14 wherein the first component of the cement is a copolymer of norbornene and ethylene.
16. The method of claim 15 wherein the third component is an ethylene and α -olefin copolymer.
17. The method of claim 15 wherein the first article and the second article are flexible.
18. The method of claim 1 wherein the first component is present in an amount of from about 1–20% by weight of the cement composition.
19. The method of claim 1 wherein the first component is present in an amount of from about 1–15% by weight of the cement composition.
20. The method of claim 1 wherein the first component is present in an amount of from about 3–15% by weight of the cement composition.
21. The method of claim 1 wherein the first article is a medical tubing of an ethylene and α -olefin copolymer or an ethylene vinyl acetate copolymer or an ethylene methacrylate copolymer and the second article is a medical housing.
22. The method of claim 21 wherein the medical housing has a modulus of elasticity of greater than about 30,000 psi as measured in accordance with ASTM D790.
23. The method of claim 1 wherein the ethylene copolymer is an ultra low density polyethylene.
24. The method of claim 1 wherein the ethylene is copolymerized with an α -olefin having 4–8 carbons.
25. A method for using a polymeric cement to assemble medical devices comprising the steps of:
- providing a first article of a low crystallinity polymer;
 - providing a second article of a low crystallinity polymer;
 - wherein the first low crystallinity polymer and the second low crystallinity polymer are selected from the group consisting of:
 - (a) a homopolymer of a polyolefin,
 - (b) a copolymer having a first monomer selected from the group consisting of propylene, butene, pentene, hexene, heptene, octene, nonene and decene,
 - (c) ethylene copolymerized with monomers selected from the group of α -olefins having 3–10 carbons,

- lower alkyl and lower alkene substituted carboxylic acids and esters and anhydride derivatives thereof,
 - (d) ethylene-propylene rubbers,
 - (e) EPDM,
 - (f) ionomers,
 - (g) homopolymers of cyclic olefins,
 - (h) copolymers of cyclic olefins selected from the group consisting of substituted and unsubstituted cyclopentene, cyclopentadiene, cyclohexene, cyclohexadiene, cycloheptadiene, cyclooctene, and cyclooctadiene, copolymerized with a fourth monomer selected from the group consisting of α -olefins having from 2–10 carbons, cyclic olefins, bridged polycyclic hydrocarbons and aromatic hydrocarbons,
 - (i) homopolymers of bridged polycyclic hydrocarbons, and
 - (j) and copolymers of bridged polycyclic hydrocarbons containing more than 7 carbons with a fifth monomer selected from the group of α -olefins having from 2–10 carbons, cyclic olefins, bridged polycyclic hydrocarbons and aromatic hydrocarbons;
- providing a cement composition comprising a first component obtained by copolymerizing a norbornene monomer and an ethylene monomer in an addition polymerization process, the norbornene monomer being present in an amount of at least about 20 mole percent of the copolymer, the first component being present in an amount from about 1% to about 20% by weight of the composition; a second component of an effective amount of a solvent having a solubility parameter of 20 (MPa)^{1/2} and a molecular weight of less than about 200 g/mole; and a third component of a first ethylene and α -olefin copolymer, the third component being present in an amount from about 0% to about 10% by weight of the composition;
- applying the cement composition to one of the first and second articles to define a bonding area; and
- attaching the first article to the second article along the bonding area to fixedly attach the first article to the second article.
26. The method of claim 25 wherein the first article is a rigid medical housing and the second article is a flexible medical tubing.
27. The method of claim 25 wherein the first article is a rigid medical housing and the second article is a semi-rigid article.
28. The method of claim 25 wherein the first article and the second article are flexible.
29. The method of claim 25 wherein the glass transition temperature of the first component of the cement composition is from about 70° C. to about 130° C.
30. The method of claim 25 wherein the first component is present in an amount from 1–15% by weight of the cement composition.
31. The method of claim 25 wherein the first component is present in an amount from 3–10% by weight of the cement composition.
32. The method of claim 25 wherein the ethylene copolymer is an ultra low density polyethylene.
33. The method of claim 25 wherein the ethylene is copolymerized with an α -olefin having 4–8 carbons.
34. A medical device assembly comprising:
- a first article of a low crystallinity polymer;
 - a second article of a low crystallinity polymer;
 - wherein the first low crystallinity polymer and the second low crystallinity polymer are selected from the group consisting of:

23

- (a) a homopolymer of a polyolefin,
 (b) a copolymer having a first monomer selected from the group consisting of propylene, butene, pentene, hexene, heptene, octene, nonene and decene,
 (c) ethylene copolymerized with monomers selected from the group of α -olefins having 3–10 carbons, lower alkyl and lower alkene substituted carboxylic acids and esters and anhydride derivatives thereof,
 (d) ethylene-propylene rubbers,
 (e) EPDM,
 (f) ionomers,
 (g) homopolymers of cyclic olefins,
 (h) copolymers of cyclic olefins selected from the group consisting of substituted and unsubstituted cyclopentene, cyclopentadiene, cyclohexene, cyclohexadiene, cycloheptadiene, cyclooctene, and cyclooctadiene, copolymerized with a fourth monomer selected from the group consisting of α -olefins having from 2–10 carbons, cyclic olefins, bridged polycyclic hydrocarbons and aromatic hydrocarbons,
 (i) homopolymers of bridged polycyclic hydrocarbons, and
 (j) and copolymers of bridged polycyclic hydrocarbons containing more than 7 carbons with a fifth monomer selected from the group of α -olefins having from 2–10 carbons, cyclic olefins, bridged polycyclic hydrocarbons and aromatic hydrocarbons;
- a cement composition fixedly attaching the first article to the second article, the composition having a first component of a polymer having a backbone containing monomers of a cyclic olefin or a bridged polycyclic hydrocarbon wherein the polymer is at least about 20 mole percent of the first component and is obtained by an addition polymerization process, and a second component of an effective amount of a solvent having a solubility parameter of less than about 20 (MPa)^{1/2} and a molecular weight of less than about 200 g/mole.
35. The device of claim 34 wherein the cyclic olefin of the cement composition has from 5 to about 10 carbons in the ring.
36. The device of claim 34 wherein the cyclic olefin of the cement composition is selected from the group consisting of substituted and unsubstituted cyclopentene, cyclopentadiene, cyclohexene, cyclohexadiene, cycloheptene, cycloheptadiene, cyclooctene, and cyclooctadiene.
37. The device of claim 34 wherein the bridged polycyclic hydrocarbon of the cement composition has at least 7 carbons.
38. The device of claim 37 wherein the bridged polycyclic hydrocarbons have at least two rings.
39. The device of claim 38 wherein the bridged polycyclic hydrocarbon is norbornene.
40. The device of claim 34 wherein the first component of the cement composition is obtained by copolymerizing the cyclic hydrocarbon or the bridged polycyclic hydrocarbon with a comonomer.
41. The device of claim 40 wherein the comonomer is selected from the group comprising α -olefins having from 2–10 carbons, aromatic hydrocarbons, cyclic olefins, and bridged polycyclic hydrocarbons.
42. The device of claim 41 wherein the first component is a copolymer of a norbornene monomer and an ethylene monomer.
43. The device of claim 42 wherein the norbornene monomer is present in at least about 20 mole percent of the copolymer.

24

44. The device of claim 43 wherein the norbornene is present from about 30 to about 60 mole percent.
45. The device of claim 43 wherein the glass transition temperature of the first component is from about 70° C. to about 130° C.
46. The device of claim 34 wherein the cement has a third component selected from the group comprising polyethylene copolymers having a density less than 0.880 g/cc, polymethyl pentene, polypropylene having a modulus of less than 10,000 psi, styrene containing copolymers and styrene and ethylene containing interpolymers.
47. The device of claim 46 wherein the first component of the cement is a copolymer of norbornene and ethylene.
48. The device of claim 47 wherein the third component is an ethylene and α -olefin copolymer.
49. The device of claim 46 wherein the first article is a medical tubing of an ethylene and α -olefin copolymer and the second article is a medical housing.
50. The device of claim 49 wherein the medical housing has a modulus of elasticity of greater than about 30,000 psi as measured in accordance with ASTM D790.
51. The device of claim 50 wherein the medical housing is of a polymeric material selected from the group of cyclic hydrocarbons and bridged polycyclic hydrocarbons.
52. The device of claim 34 wherein the first component is present in an amount from 1–20% by weight of the cement composition.
53. The device of claim 52 wherein the first component is present in an amount from 3–10% by weight of the cement composition.
54. The device of claim 34 wherein the first component is present in an amount from 1–15% by weight of the cement composition.
55. The device of claim 34 wherein the solvent has a solubility parameter of less than about 19 (MPa)^{1/2} and a molecular weight of less than about 180 g/mole.
56. The method of claim 34 wherein the ethylene copolymer is an ultra low density polyethylene.
57. The method of claim 34 wherein the ethylene is copolymerized with an α -olefin having 4–8 carbons.
58. A medical device assembly comprising:
 a first article of a low crystallinity polymer;
 a second article of a low crystallinity polymer;
 wherein the first low crystallinity polymer and the second low crystallinity polymer are selected from the group consisting of:
 (a) a homopolymer of a polyolefin,
 (b) a copolymer having a first monomer selected from the group consisting of propylene, butene, pentene, hexene, heptene, octene, nonene and decene,
 (c) ethylene copolymerized with monomers selected from the group of α -olefins having 3–10 carbons, lower alkyl and lower alkene substituted carboxylic acids and esters and anhydride derivatives thereof,
 (d) ethylene-propylene rubbers,
 (e) EPDM,
 (f) ionomers,
 (g) homopolymers of cyclic olefins,
 (h) copolymers of cyclic olefins selected from the group consisting of substituted and unsubstituted cyclopentene, cyclopentadiene, cyclohexene, cyclohexadiene, cycloheptadiene, cyclooctene, and cyclooctadiene, copolymerized with a fourth monomer selected from the group consisting of α -olefins having from 2–10 carbons, cyclic olefins, bridged polycyclic hydrocarbons and aromatic hydrocarbons,

25

- (i) homopolymers of bridged polycyclic hydrocarbons, and
- (j) and copolymers of bridged polycyclic hydrocarbons containing more than 7 carbons with a fifth monomer selected from the group of α -olefins having from 2–10 carbons, cyclic olefins, bridged polycyclic hydrocarbons and aromatic hydrocarbons; and
- a cement composition connecting the first article to the second article comprising
- a first component obtained by copolymerizing a norbornene monomer and an ethylene monomer in an addition polymerization process, the norbornene monomer being present in an amount of at least about 20 mole percent of the copolymer, the first component being present in an amount from about 1% to about 30% by weight of the composition; a second component of an effective amount of a solvent having a solubility parameter of less than about 20 (Mpa)^{1/2}; and an optional third component of a first ethylene and α -olefin copolymer, the third component being in an amount from about 0% to about 10% by weight of the composition;
- applying the cement composition to one of the first and second articles to define a bonding area; and

26

attaching the first article to the second article along the bonding area to fixedly attach the first article to the second article.

59. The device of claim **58** wherein the first article is a rigid medical housing and the second article is a flexible medical tubing.

60. The device of claim **59** wherein the first article is a rigid medical housing and the second article is a semi-rigid article.

61. The device of claim **59** wherein the first article and the second article are flexible.

62. The device of claim **58** wherein the first component of the cement composition has from about 30 to about 60 mole percent norbornene monomer.

63. The device of claim **58** wherein the glass transition temperature of the first component of the cement composition is from about 70° C. to about 180° C.

64. The method of claim **58** wherein the ethylene copolymer is an ultra low density polyethylene.

65. The method of claim **58** wherein the ethylene is copolymerized with an α -olefin having 4–8 carbons.

* * * * *